

EXPANSION JOINT IN RADIUS WHERE SIDEWALK ABUTS CURB (NEW CONSTRUCTION). EXPANSION JOINT NOT REQUIRED WHERE RAMP AND CURB POURED MONOLITHIC AS IN RETROFIT RAMP CONSTRUCTION.

REFER TO STD. DWG. ST-22D FOR RAMP DETAILS

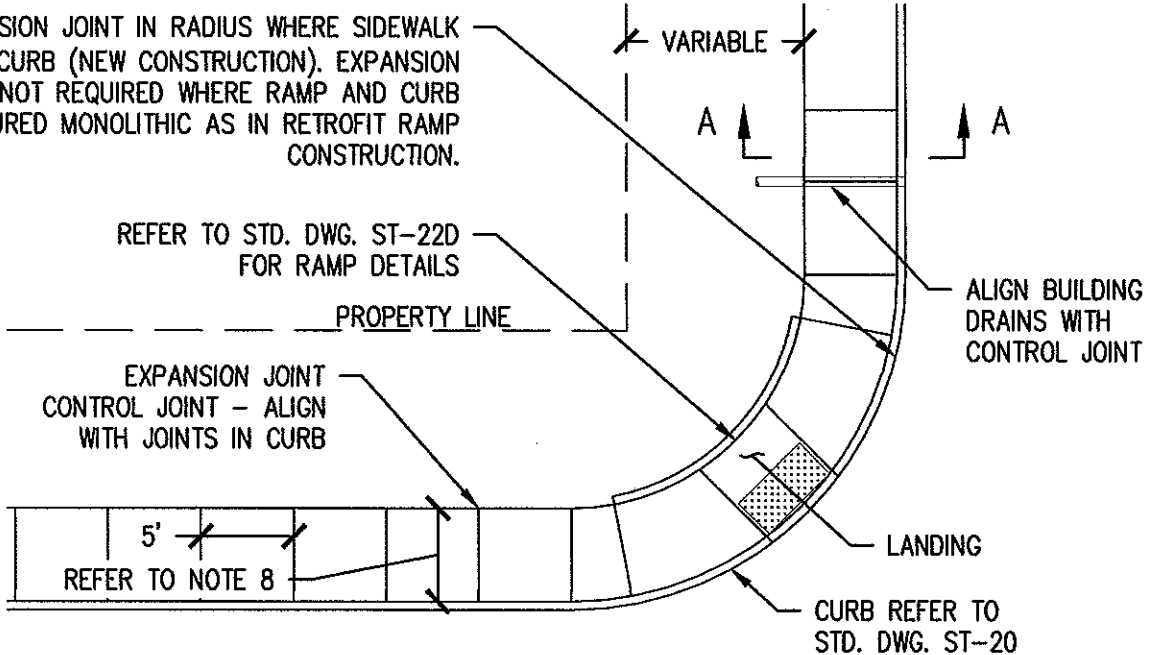

SLOPE 2H:1V MAX. VERTICAL BANKS NOT PERMITTED. CITY OF KEIZER PW DEPT. TO DETERMINE SLOPES IN EASEMENT AREAS.

REFER TO NOTE 8

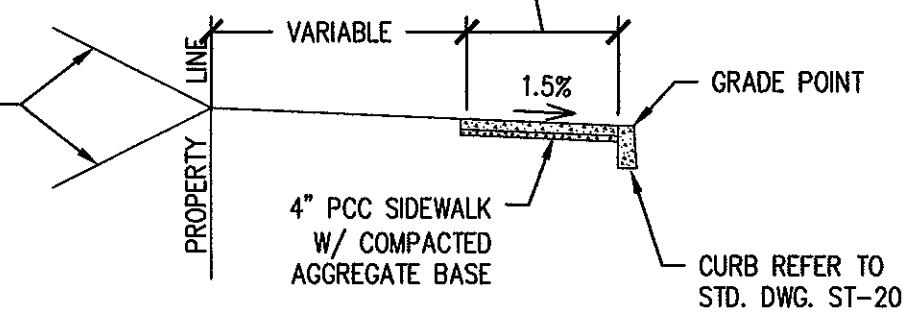

SECTION "A-A"

NOTES:

1. EXPANSION JOINTS 1/2" X 4" PREMOLDED JOINT FILLER MATERIAL AT LOCATIONS SHOWN, HEREON AND ON STANDARD DRAWING NO. 22. MATERIAL SHALL BE RECESSED OR CUT TO WITHIN 1/2" OF THE FINISHED CONCRETE SURFACE.
2. CONTROL JOINTS SHALL BE 1-1/4" DEEP, SPACED AT 5' INTERVALS.
3. 28 DAY CONCRETE STRENGTH SHALL BE 3300 P.S.I.
4. PAVEMENT, TURF, OR PLANTED AREAS DISTURBED BY SIDEWALK CONSTRUCTION SHALL BE RESTORED TO ORIGINAL CONDITION.
5. FINISH SIDEWALK WITH LIGHT TRANSVERSE BROOMING EXCEPT AT RAMPS.
6. ALL EDGES SHALL BE TOOL ROUNDED AND SHINED (3") AFTER BROOMING.
7. SEE STD. DRAWING ST-24 FOR STD. SIDEWALK DEPTHS AT MAILBOX LOCATIONS.
8. 5' MIN. SIDEWALK WIDTH FOR LOCAL STREETS - 6' MIN. SIDEWALK WIDTH FOR ARTERIAL AND COLLECTOR STREETS. SLOPE 1.5% TYPICAL, 2% MAXIMUM



CITY OF KEIZER

DEPARTMENT OF PUBLIC WORKS

CURB LINE SIDEWALK

DRAWN: G.H.B.

DATE: 12-21-16

APPROVED: W.I.P.

NUMBER: ST-22A