



TOWNSHIP OF NUTLEY
1 KENNEDY DRIVE • NUTLEY, NJ 07110
PHONE: 973-284-4957 • FAX: 973-284-0071



POOL GUIDE

1. This handout is based on the 2009 New Jersey Edition of the International Residential Code, the 2011 National Electrical Code, and Chapter 700 of the Township of Nutley Zoning Code. This is only a guide and cannot cover every situation that you may encounter or have.
2. All proposed pools require approvals of the Zoning Officer and Building Department before a construction permit may be issued.
3. Permit applications are required for all hot tubs, spas, in-ground pools, semi-in-ground pools, and above ground pools that contain water over 24 inches deep.
4. All permits shall require a building, plumbing and electrical permit. If a gas-fired heater is being installed, a fire protection permit is required.
5. Zoning requirements for a non-commercial swimming pool as an accessory use, shall be subject to the following. **Pool and all equipment to be located:**
 - a. Rear 50% of property.
 - b. Minimum of 8' from sides and rear property lines.
 - c. Minimum of 10' from main structure.
 - d. All pumps, heaters and filtration systems shall be kept at a maximum distance from all property lines and shall be at least 4' from any property line
 - e. Minimum of 50' from front property line and 25' from side street (corner lot)
 - f. Total of all accessory structures, including pool, may not exceed 30% of the rear yard.
 - g. Total structures on premises may not exceed 35% maximum lot coverage.
 - h. Minimum 4' approved (NON-CLIMBABLE) fence (in ground pool and semi-in ground pools)
 - i. Maximum impervious surface area for R-1AA zone is 60%, R-1A zone is 65%, R-1 and R-2 zones is 70%
 - j. Decks attached to a pool must be 8' from the property line.
 - k. NOTE: Outside lighting installed shall not create glare or annoyance to adjoining properties
6. The following must be submitted with the application
 - a. Three (3) site plans indicating (***Note: site plans must be to scale**)
 1. Size, shape and location of pool.
 2. Size, shape and location of all other permanent structures.
 3. Location and description of permanent fence enclosure including all proposed self-closing, self-latching gates with lock.
 4. Location and description of filtration and pool heating systems.
Location means: The proposed distance of the equipment to the property lines, **to scale**
 5. Existing and proposed elevations of final grade and elevation of pool. (in ground pool only)

7. Above ground pools: Manufacturers installation instructions for pool, filtration systems and accessories are required. If a deck is being built, three (3) copies of the plans are required. NOTE: Above ground pool fence enclosure requirements can be waived when it can be demonstrated that:
 - a. The pool has smooth sides that won't permit climbing by small children.
 - b. Is a minimum of 48" high above grade.
 - c. Filtration systems are a minimum of 36" from sidewall of pool and cannot be used as a steppingstone to gain access into pool.
 - d. Location of the fence enclosure showing the gate location and latching operation, in conformance with code.

8. Permanent In-ground Pool – Three (3) sets of signed and sealed structural pool plan (by licensed New Jersey Architect or Engineer) Semi-In-ground Pool – shall require a letter from a licensed New Jersey Engineer on pool being buried and filled.
 - a. In order to expedite the permit process these plans must indicated, but are not limited to (when applicable):
 1. Volume of water in the pool.
 2. The following diving board information:
 - a. Length of board and projection into pool area.
 - b. Height above water, and water depth at end of diving board.
 3. Egress from deep end, general: ladder
 4. Egress from shallow end, general: steps
 5. Location of the fence enclosure showing the gate location and latching operation.

9. Manufacturer's specifications are required for pool heaters.
 - a. Gas heaters require review by the Fire Subcode Official and Plumbing Subcode Official.
 - b. Electric heaters require review by the Electric Subcode Official.

10. All swimming pool applications must be reviewed by the Plumbing Official.
 - a. Plumbing diagrams are required for gas pipe and water feeds.
 - b. Manufacturer's brochure are required for filtration and pump systems.
 - c. All requirements for entrapment protection must be met
 - d. Backflow preventer on water spigot is required.

11. Electrical plans and specifications must be review by Electrical Official and must comply with the 2011 National Electrical Code, Article 680.

AN ELECTRICAL SCHEMATIC IS REQUIRED BY THE TOWNSHIP FROM HOMEOWNERS, AS WELL AS ELECTRICIANS, FOR ALL PROPOSED WORK.

This sketch must include the following:

- a. Type of conduit (PVC, rigid metallic, IMC)
- b. Burial depth – 18 inches, burial depth may be reduced to 12 inches (see inspector)
- c. Wire size and type (#12 awg minimum copper THWN – THWN properly color coded)
- d. Location and type of GFI protection if required.
- e. Pump outlet specifications and location or pump outlet.
 1. Single locking receptacle 6' from pool ground fault protected.
 2. Pump may be hard wired with disconnect (in-ground pool only)
- f. Accessories such as pool lights, skimmer, etc.
- g. Bonding details.

- h. Convenience outlet GFI protected between 10 to 20 feet of pool.
- i. Install an equipment grounding conductor, no smaller than #12 insulated copper from panel to pool motor. 680-25-C
- j. Pool bonding wire to be #8 solid (bare) and bonded to pool in 4 spots.

This information should be shown as an electrical one-line diagram on a plan view of the property. In addition a copy of manufacturers' brochure and all electrical equipment associated with the pool is required.

Strict compliance with Article 680 of the 2011 National Electrical Code is required.

12. Pool Enclosure Requirements

A barrier, such as a fence or wall, must surround private swimming pools. The barrier must meet the following requirements:

- a. The top of the barrier shall be at least **48 inches** above finished ground level measured on the side of the barrier, which faces away from the swimming pool. The maximum vertical clearance between finished ground level and the bottom of the barrier shall be 2 inches measure on the side of the barrier, which faces away from the swimming pool. Where the top of the pool structure is above finished ground level, such as an above ground pool, the barrier shall be at finished ground level, such as an above ground pool, the barrier shall be at finished ground level, such as the pool structure, or shall be mounted on top of the pool structure. Where the barrier is mounted on the pool structure, the opening between the top surface of the pool frame and the bottom of the barrier shall not allow passage of a 4-inch diameter sphere.
- b. Openings in the barrier shall not allow passage of a **4-inch** diameter sphere.
- c. Solid barriers shall not contain indentations or protrusions except for normal construction tolerances and tolled masonry joints
- d. Where the barrier is composed of horizontal and vertical members and the distance between the tops of the horizontal members is less than 45 inches, the horizontal members shall be located on the swimming pool side of the fence. Spacing between vertical members shall not exceed 1 ¾" in width. Decorative cutouts shall not exceed 1 ¾" in width
- e. Where the barrier is composed of horizontal and vertical members and the distance between the tops of the horizontal members is 45 inches or more, spacing between vertical members shall not exceed 4 inches. Decorative cutouts shall not exceed 1 ¾ inches in width

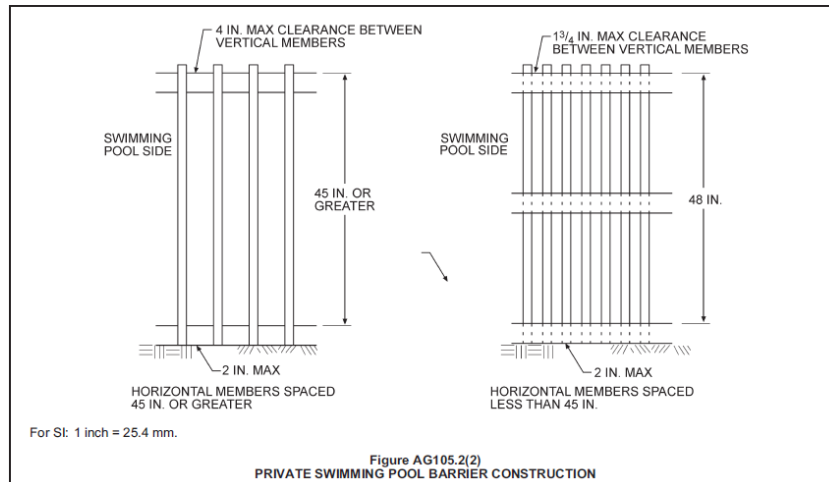

- f. Maximum mesh size for chain link fences shall be a 2 1/4" square unless the fence is provided with slats fastened at the top or bottom which reduce the openings to not more than 1 3/4"

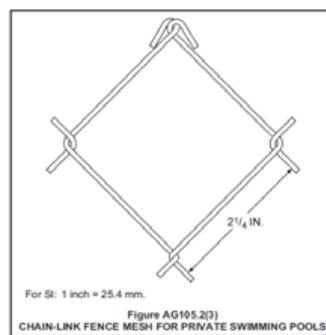

- g. Where the barrier is composed of diagonal members, such as lattice fence, the maximum opening formed by the diagonal members shall not be more than 1 3/4".
- h. Access gates shall comply with the requirements of items "a" through "g", and shall be equipped to accommodate a locking device. Pedestrian access gates shall open outwards away from the pool and shall be self-closing and have a self-latching device. Where the release mechanism of the self latching device is located less than 54" from the bottom of the gate: (a) the release mechanism shall be located on the pool side of the gate at least 3" below the top of the gate; and (b) the gate the barrier shall not have an opening greater than 1/2" within 18" of the release mechanism.

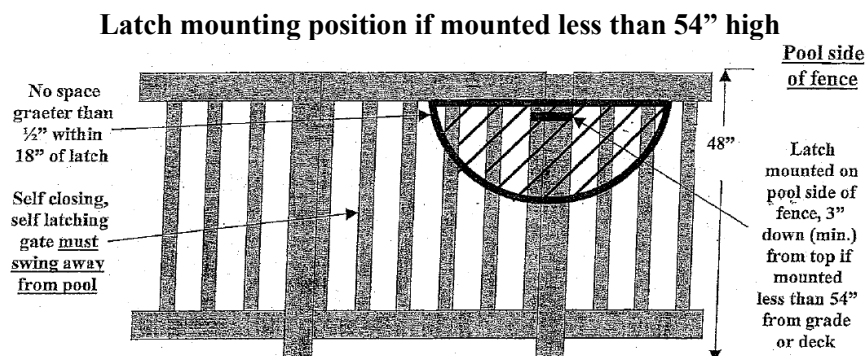

If latch is mounted less than 54" from grade, it must be mounted on the **pool** side of the gate, a minimum of 3" down from the top of the gate and have no space greater than 1/2" within 18" of the latch

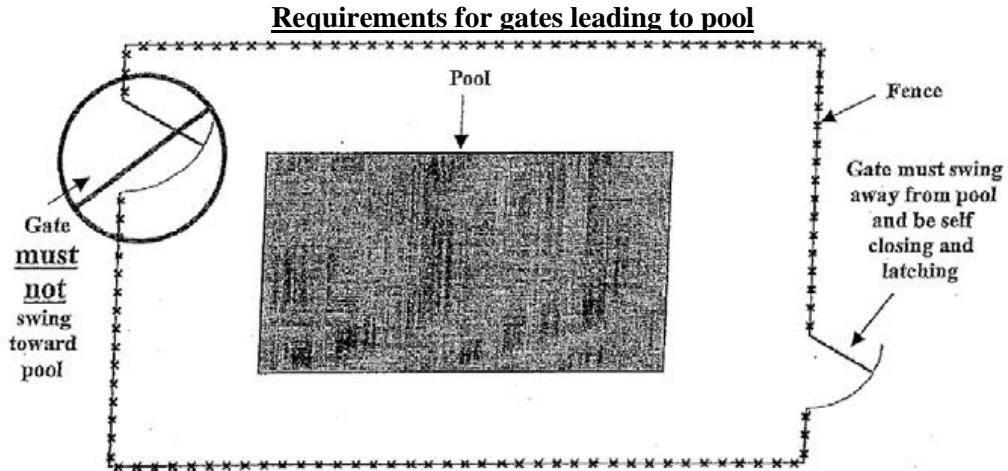

- i. Where an above-ground pool structure is used as a barrier or where the barrier is mounted on top of the pool structure, and the means of access is fixed or removable ladder or steps, the ladder or steps, the ladder or steps shall be surrounded by a barrier, which meets the requirements of items "a" through "h". **A removable ladder shall not constitute an acceptable alternative to enclosure requirements.**

Ladder Enclosure



(This is a sample only of an accepted ladder enclosure)

Maximum Space Between Top Mounted Barrier and Pool Wall

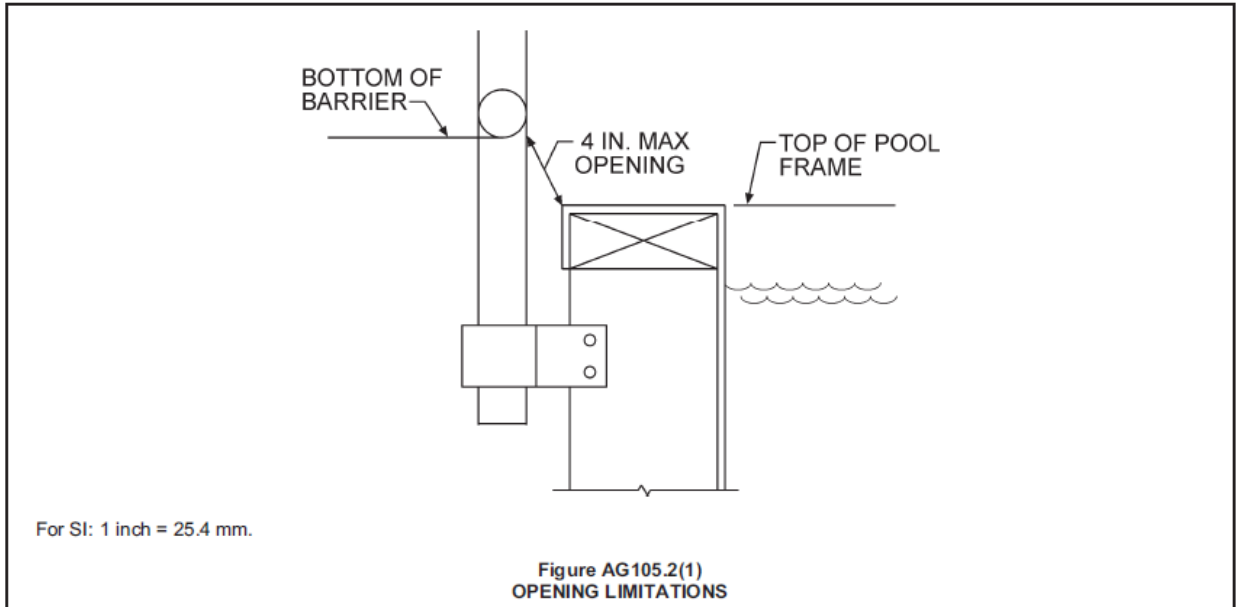

Pool With Top Mounted Barrier and Stair Gate



- j. Where an above ground pool on a sloped site what will make a portion of the top of the pool structure to be less than 48" to grade, a minimum of 3' level surface around the portion of the pool structure that is less than 48" to grade should be provided. The level surface should be measure away from the pool wall to the excavation edge and should be tapered away from the pool at a minimum of 45-degree angle for a distance of one half the level surface. (Figure 10)

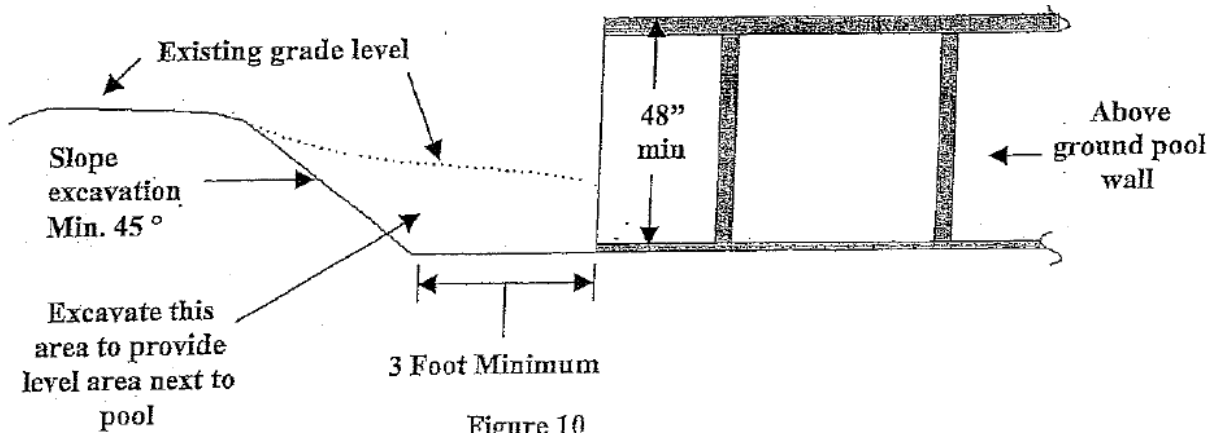

Figure 10

13. NOTE: A temporary fence is required during pool construction. It must be of adequate structural integrity to prevent small children, the blind, the mentally handicapped, and people under the influence of alcohol or drugs from gaining access to pool area.

INSPECTION REQUIREMENTS FOR POOLS

ABOVE GROUND POOLS

1. Electrical – **ROUGH, BONDING, and TRENCH.** (*Do not energize or seal any equipment until inspection passes*)
2. Plumbing – **PIPE, TRENCH, and AIR TEST.** (Pool Heater if applicable)
3. Final Electrical
4. Final Plumbing
5. Final Fire (Pool Heater if applicable)
6. Final Building – *All permanent fencing and/or barriers need to be installed in order to have final inspection.*

INGROUND POOLS

1. Footing – **AFTER** concrete collar is poured as per manufacturer specifications
2. Pool Steel – **PRIOR** to placement of concrete or gunite.
3. Electrical – **BONDING**
4. Electrical – **PIPE and TRENCH**
5. Plumbing – **PIPE, TRENCH, and AIR TEST.** (Pool Heater if applicable)
6. Final Electrical – **INCLUDING BONDING AROUND POOL**
7. Final Plumbing
8. Final Fire (Pool Heater if applicable)
9. Final Building – *All permanent fencing and/or barriers need to be installed in order to have final inspection.*

(Other inspections may be required depending on the scope of the project. Consult the Subcode Official if you have any questions.)

No pool is to be used until all final inspections are made and a Certificate of Approval is acquired. A Certificate of Approval requires final electrical, plumbing, fire and building inspection approvals.

**IF YOU HAVE ANY FURTHER QUESTIONS PLEASE FEEL FREE TO CALL:
DAVID BERRY, 973-284-4957**